

These drawings and specifications are the property of H2W Technologies, Inc. They are issued in confidence and shall not be reproduced, copied, or used without written permission from H2W Technologies, Inc.

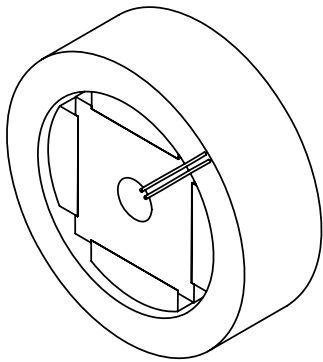
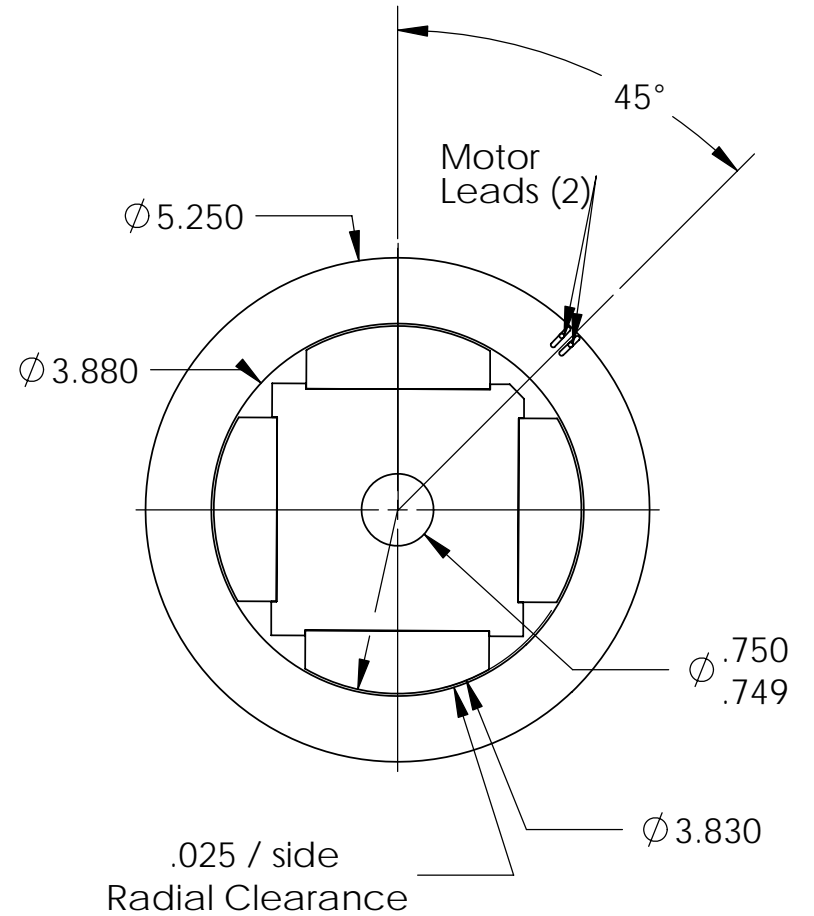
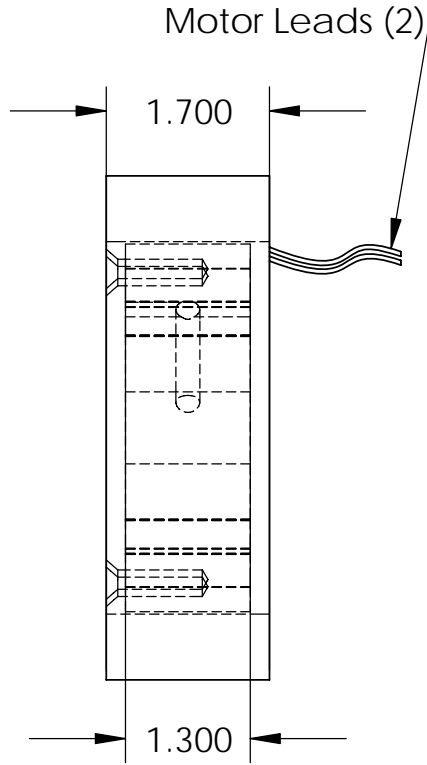
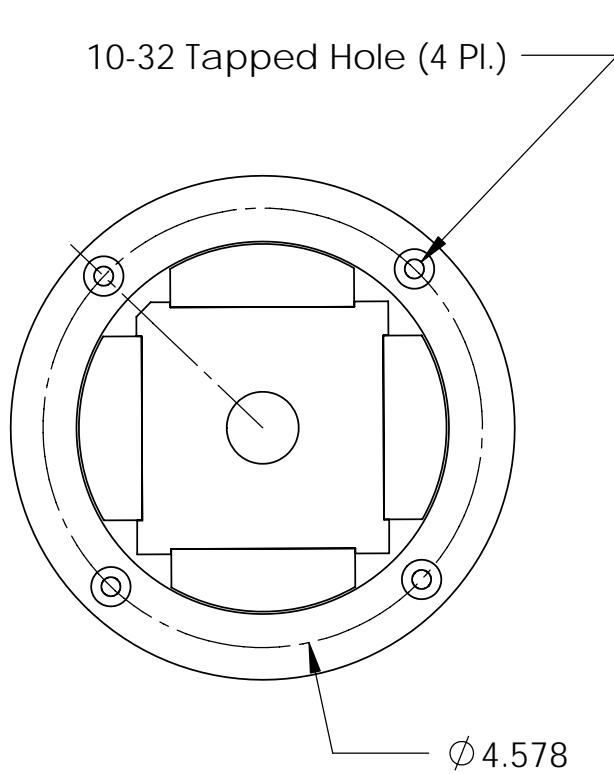

SPECIFICATIONS	
Model Number:	TMR-020-270-4V
Constant Torque Angular Displacement:	20 degrees
Resistance:	9.7 ohms
Total Weight:	3000 grams
Continuous Torque:	265 in-oz
Peak Torque:	795 in-oz
Motor Constant:	94.0 in-oz/sqrt(watts)

**H2W Technologies, Inc.**

28310-C Ave Crocker Valencia, CA 91355 USA  
Tel: (661)-702-9346 Fax: (661)-702-9348  
www.h2wtech.com

UNLESS SPECIFIED OTHERWISE:  
All dimensions are in inches  
Standard Tolerances are as follows  
.XXX ±.005 ANGLES ±1°  
XX ±.010 FILLETS AND  
X ±.020 CORNERS .010  
Remove All Burrs and Sharp Edges

MATERIAL			
FINISH			
DRAWN	DATE	APPROVED	DATE
JRM	9-19-03	MPW	9-19-03

TITLE			
TMR-020-270-4V			
DWG #	REV	ECN	
80-0074	---		